

DO NOT SCALE
DIMENSIONS IN mm

METRIC



NOTES:

- ▲ FOR USE ON STANDARD APPLICATORS. (RIGHT-LEFT FEED)
- ▲ FOR USE ON MINIATURE APPLICATORS. (LEFT-RIGHT FEED)
- ▲ FOR USE ON MINIATURE APPLICATORS, AMP O-MATOR APPLICATION. (LEFT-RIGHT FEED)

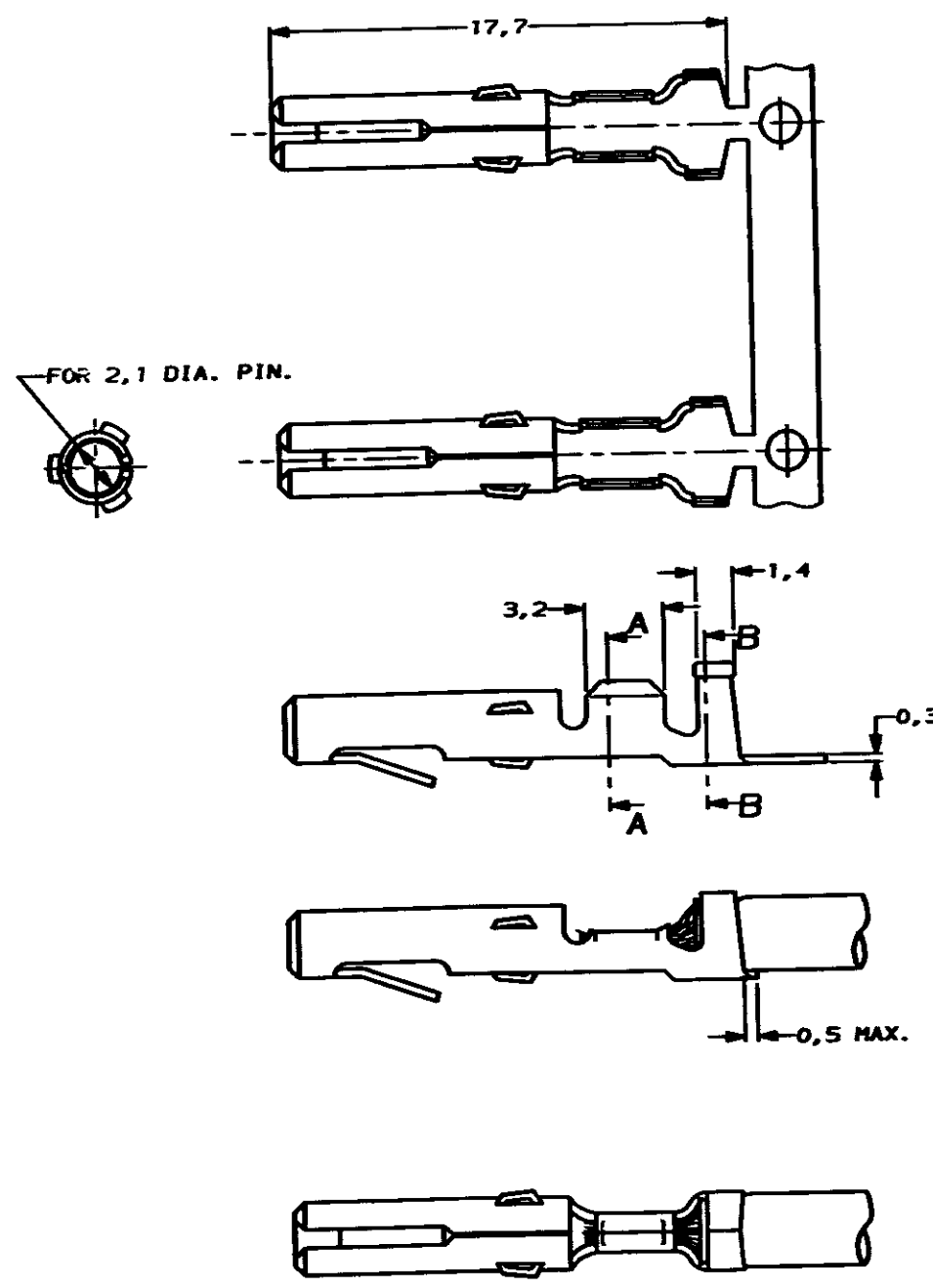

DOC. CENTRE
02 JULI 1992

WIRE RANGE :
0,5-1,0mm² AWG
INSULATION RANGE :
1,8-3,3mm DIA.

| | | | |
|---|---------------|--------------|------------|
| ▲ | SEL. GOLD | BRASS | 8-163300-1 |
| ▲ | PRE-TINPLATED | BRASS | 1-163300-5 |
| ▲ | PRE-TINPLATED | PHOSPHOR BR. | 163300-8 |
| ▲ | UNPLATED | PHOSPHOR BR. | 163300-7 |
| ▲ | PRE-TINPLATED | BRASS | 163300-6 |
| ▲ | UNPLATED | BRASS | 163300-5 |
| ▲ | PRE-TINPLATED | PHOSPHOR BR. | 163300-4 |
| ▲ | UNPLATED | PHOSPHOR BR. | 163300-3 |
| ▲ | PRE-TINPLATED | BRASS | 163300-2 |
| ▲ | UNPLATED | BRASS | 163300-1 |
| | PLATING | MATERIAL | PARTNUMBER |

| | | | | | |
|--|-----------------|---------|----------|---|-----------|
| CUSTOMER DRAWING | | | | FOR REFERENCE ONLY WILL NOT BE UPDATED | |
| © COPYRIGHT 19- BY AMP HOLLAND B.V. ALL INTERNATIONAL RIGHTS RESERVED. AMP PRODUCTS MAY BE COVERED BY U.S. AND FOREIGN AND/OR PATENTS PENDING. THIS DRAWING IS UNPUBLISHED RELEASED FOR PUBLICATION | | | | | |
| AMP | | | | AMP HOLLAND B.V. 's-Hertogenbosch, The Netherlands. | |
| J | H-9701 | JvdH AB | 13-04-92 | NAME SOCKET MATE-N-LCK. | |
| LTR. | REVISION RECORD | DR. | CHK. | DATE | |
| DR. | J.V.B.MELDER | CHK. | A.B.MEK | APP. | L.V.SEST. |
| DATE. | 10-04-92 | DATE. | - | DATE. | 29-4-92 |
| Dwg. No. C-163300 | | | | REV. LTR. | SHEET |
| | | | | J | 1 of 1 |
| | | | | A3 | |